

Dimensional Drawing : Foot Mounted (B3 Construction) TEFC Standard Motors Frame 63-315M

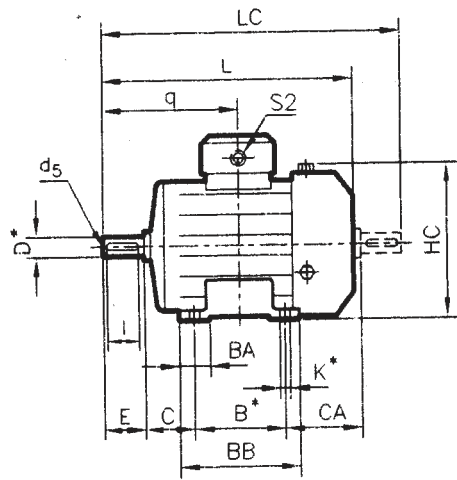

FRAME SIZE 63, 71 & 80

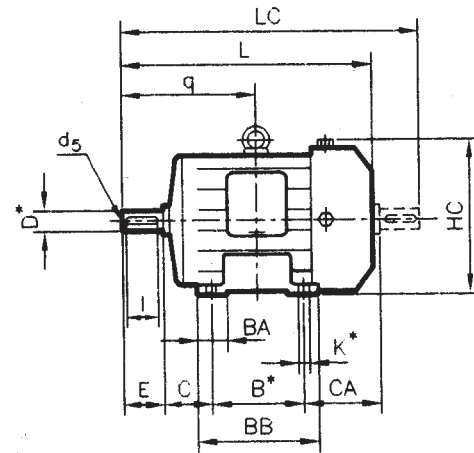
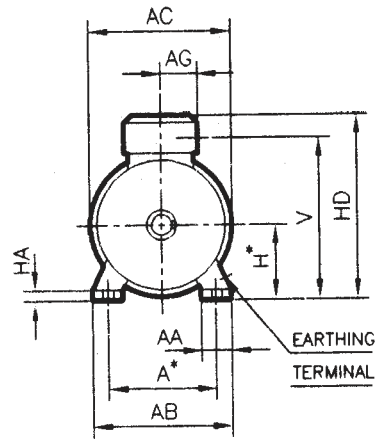

FRAME SIZE 90S TO 160L

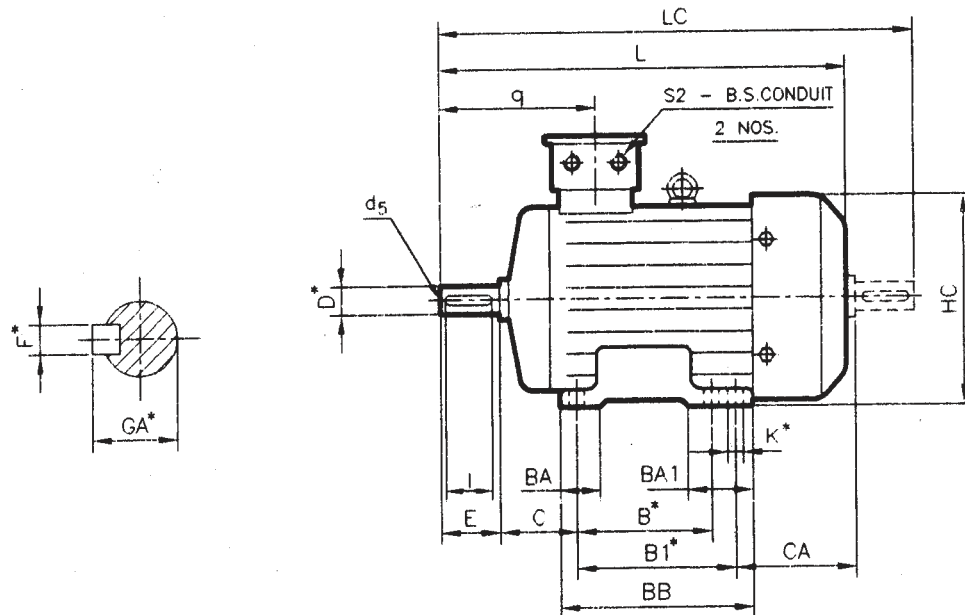
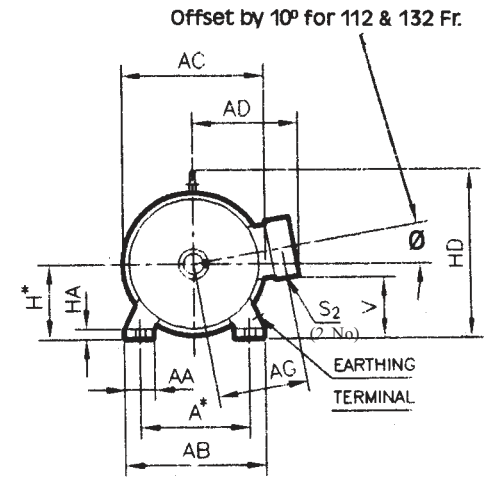

FRAME SIZE 180 TO 315S/M

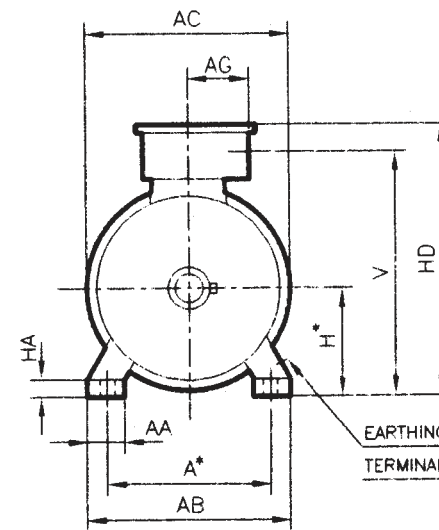

Dimensional Details : Foot Mounted (B3 Construction) TEFC Standard Motors Frame 63-315M

IEC Frame Size	Motor Type	FIXING				GENERAL														TERMINAL BOX			SHAFT								
		A*	B*	B1*	C	H*	K*	AB	BB	AA	BA	BA1	HA	HC	HD	AD	L	LC	CA	AC	V	q	AG	S2	D*	E	F*	GA*	I	d	
63	MA 063	100	80	-	40	63	7	126	100	30	28	-	7	128	177	-	206	241	75	124	149	103	40	3/4"	11	23	4	12.5	18	M 4	
71	MA 071	112	90	-	45	71	7	138	110	30	29	-	7	143.5	191	-	234	278	83	139	163	120	40	3/4"	14	30	5	16	25	M 5	
80	MA 080	125	100	-	50	80	10	153	124	32	32	-	10	161	207	-	267	324	94	157	179	110	40	3/4"	19	40	6	21.5	35	M 6	
90S	MA 09S	140	100	-	56	90	10	168	150	34	54	-	12	177	①	142	327	399	143	172	34	169	104	3/4"	24	50	8	27	45	M 8	
90L	MA 09L	140	125	-	56	90	10	168	150	34	54	-	12	177	①	142	327	399	143	172	34	169	104	3/4"	24	50	8	27	45	M 8	
100L	MA 10L	160	140	-	63	100	12	190	174	44	36	-	14	198	235	162	366	448	125	196	44	193	125	1"	28	60	8	31	55	M 10	
112M	MA 11M	190	140	-	70	112	12	230	176	62	50	-	15	226	269	182	388	471	141	226	82	200	144	1"	28	60	8	31	55	M 10	
132S	MA 13S	216	140	-	89	132	12	256	180	64	50	-	17	266	308	206	449	552	163	266	99	239	166	1"	38	80	10	41	70	M 12	
132M	MA 13M	216	178	-	89	132	12	256	218	64	54	-	17	266	308	206	487	590	163	266	99	258	166	1"	38	80	10	41	70	M 12	
160M	MA 16M	254	210	-	108	160	15	306	256	74	65	-	20	322	366	226	605	741	183	324	131	323	186	1"	42	110	12	45	105	M 16	
160L	MA 16L	254	254	-	108	160	15	306	300	74	65	-	20	322	366	226	649	785	183	324	131	345	186	1"	42	110	12	45	105	M 16	
180M/L	MA 18M/L	279	241	279	121	180	15	344	319	65	70	108	26	357	462	-	717	821	201	354	410	264	112	1-1/2"	48	110	14	51.5	100	M 16	
200L	MA 20L	318	305	-	133	200	19	398	355	85	65	65	32	397	512	-	793	944	234	394	449	287	172	2"	55	110	16	59	100	M 20	
225S/M	MA 22S/M	* A	356	286	311	149	225	19	436	361	85	85	110	34	447	562	-	825	974	239	444	498	297	172	2"	55	110	16	59	100	M 20
			* B																830	949	239	444	498	327	172	2"	60	140	18	64	130
250M	MA 25 M	* A	406	349	-	168	250	24	506	425	100	115	115	42	498	665	-	915	1065	268	495	578	352	205	2"	60	140	18	64	130	M 20
			* B																								65	140	18	69	130
280S/M	MA 28S/M	* A	457	368	419	190	280	24	557	525	100	145	155	42	552	725	-	1010	1160	271	544	638	360	205	2"	65	140	18	69	130	M 20
			* B																								75	140	20	79.5	130
315S/M	MA 31S/M	* A	508	406	457	216	315	28	625	541	100	115	155	45	629	830	-	1133	1273	406	604	728	386	218	2"	65	140	18	69	130	M 20
			* B																1163	1333	457						80	170	22	88.5	160

Tolerance on Dimensions with

Dimension	Tolerance		Specification
A, B	±0.75	IS	IS : 1231
H	0.5	IS	IS : 1231
D	j6	11,14,19,24,28Ø	
	k6	38,42,48Ø	
	m6	55,66Ø,65Ø,75,80	
K	+0.360	10Ø	
	+0.430	12,15Ø,19Ø,24Ø	
GA, F			IS : 2048
d(centering)			IS : 2540

Note :

- All Dimensions are in mm unless otherwise specified*
- ① Without Eye bolt.
 - ☐ For 225 S/M-4,6,8 pole Non Drive Shaft Extension will be limited to 55mm dia
 - ☐ *A-2 pole, *B-4, 6 & 8 pole.
 - ☐ Also suitable for B6, B7, B8, V5 & V6 mounting as per IS 2253.
 - ☐ For 280 S/M 4,6 & 8 pole Non Drive Shaft Extension will be limited to 65 mm dia.

Dimensional Drawing : Flange Mounted (B5 Construction) TEFC Standard Motor Frames 63-315 M

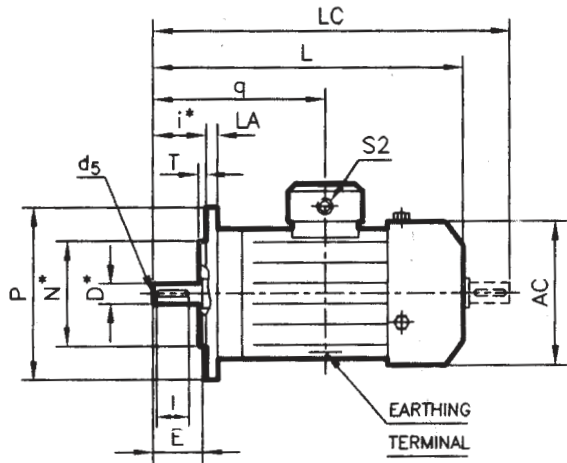

FRAME SIZE 63, 71 & 80

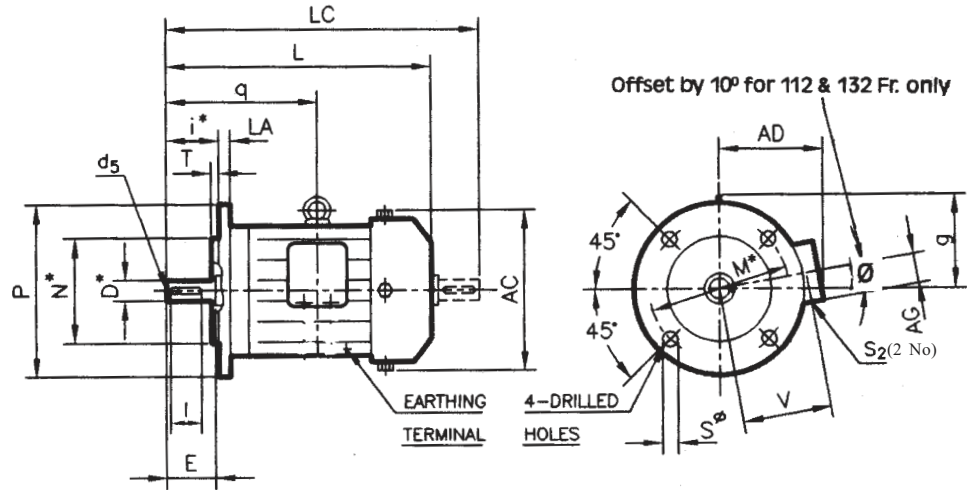

FRAME SIZE 90S TO 160L

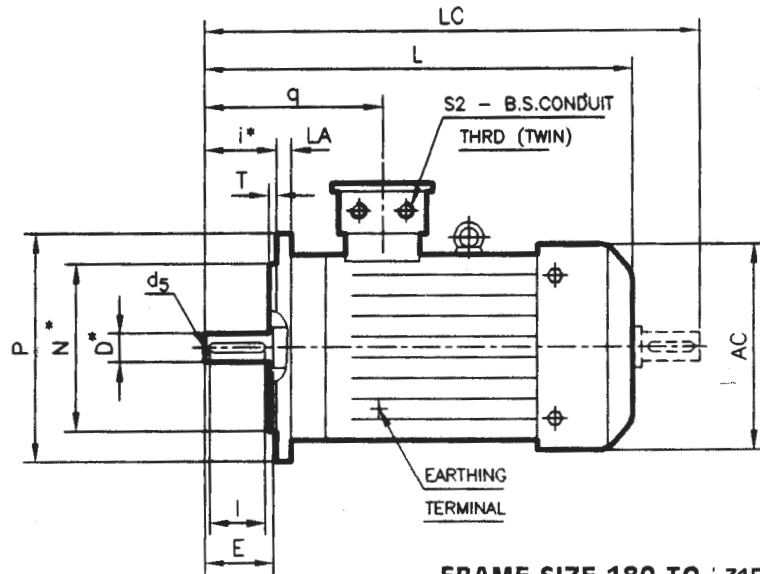
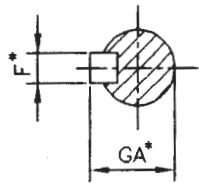

FRAME SIZE 180 TO 315S/M

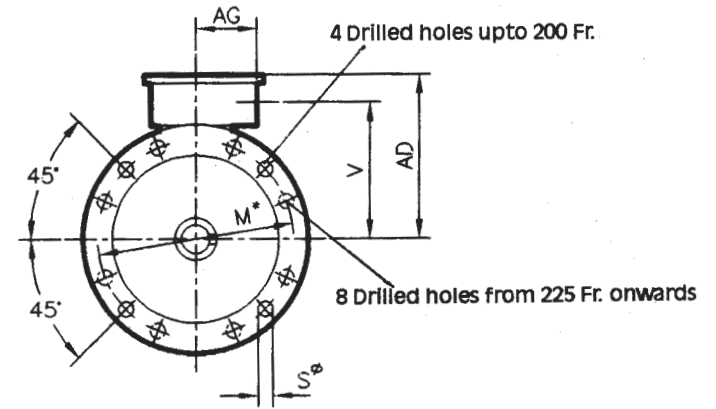

Dimensional Details : Flange Mounted (B5 Construction) TEFC Standard Motor Frames 63-315 M

IEC Frame Size	Motor Type	FIXING				GENERAL								TERMINAL BOX			SHAFT							
		P	N*	M*	i*	S	T	LA	AD	AC	L	LC	g	v	q	AG	S2	D*	E	F*	GA*	i	d	
63	MA 063	140	95	115	23	10	3	9	114	124	225	260		86	122	40	3/4"	11	23	4	12.5	18	M 4	
71	MA 071	160	110	130	30	10	3.5	9	120	139	261	305		92	147	40	3/4"	14	30	5	16	25	M 5	
80	MA 080	200	130	165	40	12	3.5	10	127	157	267	324		99	110	40	3/4"	19	40	6	21.5	35	M 6	
90S	MA 09S	200	130	165	50	12	3.5	10	142	181	327	399	①	104	156	52	3/4"	24	50	8	27	45	M 8	
90L	MA 09L	200	130	165	50	12	3.5	10	142	181	327	399	①	104	169	52	3/4"	24	50	8	27	45	M 8	
100L	MA 10L	250	180	215	60	15	4	11	162	202	366	448	135	125	193	56	1"	28	60	8	31	55	M10	
112M	MA 11M	250	180	215	60	15	4	11	182	227	388	471	157	144	200	56	1"	28	60	8	31	55	M10	
132S	MA 13S	300	230	265	80	15	4	12	206	267	449	552	176	166	239	63	1"	38	80	10	41	70	M12	
132M	MA 13M	300	230	265	80	15	4	12	206	267	487	590	176	166	258	63	1"	38	80	10	41	70	M12	
160M	MA 16M	350	250	300	110	19	5	13	226	324	605	741	206	186	323	63	1"	42	110	12	45	105	M16	
160L	MA 16L	350	250	300	110	19	5	13	226	324	649	785	206	186	345	63	1"	42	110	12	45	105	M16	
180M/L	MA 18M/L	350	250	300	110	19	5	13	282	369	717	821		230	264	112	1 1/2"	48	110	14	51.5	100	M16	
200L	MA 20L	400	300	350	110	19	5	15	312	405	793	944		249	287	172	2"	55	110	16	59	100	M20	
225S/M	MA 22S/M	* A	450	350	400	110	19	5	16	337	455	825	974		273	297	172	2"	55	110	16	59	100	M20
		* B	450	350	400	140	19	5	16	337	455	830	949		273	327	172	2"	60	140	18	64	130	M20
250M	MA 25 M	* A	550	450	500	140	19	5	16	415	495	915	1065		328	352	205	2"	60	140	18	64	130	M20
		* B																	65	140	18	69	130	M20
280S/M	MA 28S/M	* A	550	450	500	140	19	5	18	445	544	1010	1160		358	360	205	2"	65	140	18	69	130	M20
		* B																	75	140	20	79.5	130	M20
315S/M	MA 31S/M	* A	660	550	600	140	24	6	22	515	604	1133	1273		413	386	218	2"	65	140	18	69	130	M20
		* B				170													80	170	20	88.5	160	M20

All Dimensions are in mm unless otherwise specified

Tolerance on Dimensions with

Dimension	Tolerance	Specification
N	j 6	IS : 2223
M	± 0.3	
	± 0.5	
i	± 1	IS : 2048
	± 1.5	
D	j 6	IS : 2540
	k 6	
	m 6	
GA, F d(centering)	550, 600, 650, 750, 800	

Note :

- ① Without Eye bolt.
- *A-2 Pole; *B-4, 6 & 8 Pole.
- 8 Nos. Fixing Holes for 225 S/M Frame.
- Suitable for V1 V3 & B5 mounting as per IS 2253 : 1974.
- Key/Key way fit : h9 / N9
- Double shaft extension can be provided with shaft dimension identical to D.E. shaft except for 225 S/M-4, 6, 8 pole and 280 S/M-4, 6, 8 pole where Non Drive Shaft Extension will be limited to 55 m.m. dia and 65 mm dia respectively.

9



Dimensional Drawing : Face Mounted (B14 Construction) TEFC Standard Motor Frames 63 - 132 M

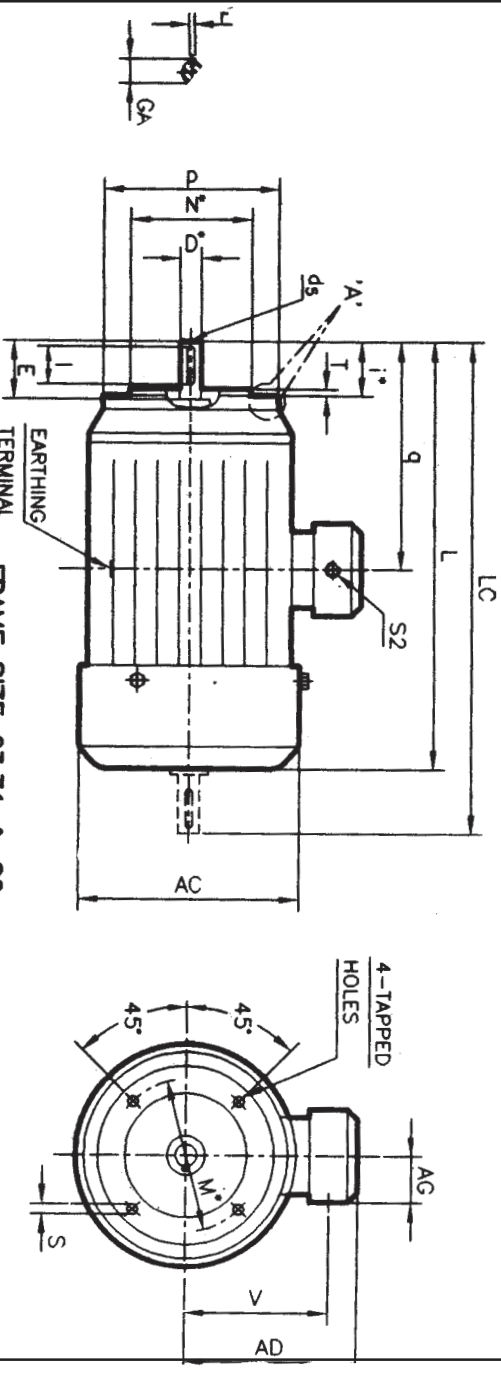

FRAME SIZE 63,71 & 80

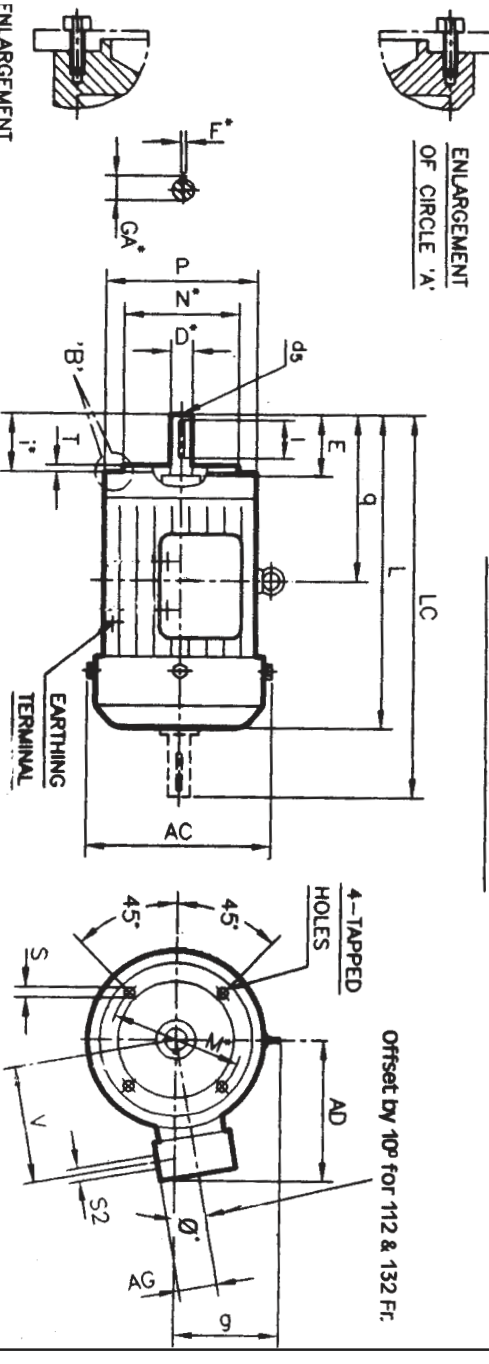

FRAME SIZE 90S TO 132M

Dimensional Details : Face Mounted (B14 Construction) TEFC Standard Motor Frames 63 - 132 M

IEC Frame Size	Motor Type	FIXING				GENERAL				TERMINAL BOX				SHAFT										
		P	N*	M*	I*	S	T	AD	AC	L	LC	g	V	q	AG	S2	D*	E	F*	GA*	i	d*		
63	MA 063	90	60	75	23	M5X10	2.5	114	124	206	241	86	103	40	3/4"	11	23	4	12.5	18	M4			
71	MA 071	105	70	85	30	M6X13	2.5	120	139	234	278	92	120	40	3/4"	14	30	5	16	25	M5			
80	MA 080	120	80	100	40	M6X13	3	127	157	267	324	99	110	40	3/4"	19	40	6	21.5	35	M6			
90S	MA 09S	140	95	115	50	M8X12	3	142	172	327	399	104	156	52	3/4"	24	50	8	27	45	M8			
90L	MA 09L	140	95	115	50	M8X12	3	142	172	327	399	104	169	52	3/4"	24	50	8	27	45	M8			
100L	MA 10L	160	110	130	60	M8X12	3.5	162	196	366	448	135	125	193	56	1"	28	60	8	31	55	M10		
112M	MA 11M	160	110	130	60	M8X12	3.5	182	227	388	471	157	144	200	56	1"	28	60	8	31	55	M10		
132S	MA 13S	250	180	215	80	M12X12	4	206	267	449	552	176	166	239	63	1"	38	80	10	41	70	M12		
132M	MA 13M	250	180	215	80	M12X12	4	206	267	487	590	176	166	258	63	1"	38	80	10	41	70	M12		

All Dimensions are in mm unless otherwise specified

Dimension	Tolerance	Specification
N	± 0.3	IS : 2223
M	+ 0.3	
i	+ 1	
D	j6 Upto 28 k6 Over 28	
d	GA, F (centering)	IS : 2048 IS : 2540

Note :

- ① With Eyebolt Suitable for B14, V19 & V18 mounting as per IS 2223.
- Key/Key way fit : h9 / N9
- Double shaft extension can be provided with shaft dimension identical to D.E. shaft.

Note : *BBL type references have changed. Please refer to page No.11 for conversion Chart.