

Sanitary Centrifugal Pumps

W+ series



W+ - Advanced Design for Performance and Reliability

SPX is a leading innovator of solutions with decades of experience in centrifugal pump design, covering premium brands such as APV and Waukesha Cherry-Burrell. From the supply of engineered components to complete process engineering and design, we specialise in helping our customers improve their plant's performance and profitability. Years of intensive product development on a worldwide scale, has enabled SPX to offer a complete range of hygienic pumps in the brewery, dairy, food, beverage, chemical, health care and pharmaceutical industries.

Features and Benefits of the W+ Pump:

- Reliable and heavy duty design
- Energy efficient
- Quiet performance with minimal vibration
- Superior shaft seal design
- High pressure capability
- 3A and EHEDG (European Hygienic Engineering & Design Group) certified.
- Designed for CIP (Cleaning In Place) as well as SIP (Sterilizing In Place)
- Suitable for wide variety of food, beverage and pharmaceutical products
- Wide range of optional features available
- Easy and cost effective maintenance



Designed for Efficiency

The W+ pump series is based on a unique hydraulic design that ensures maximum efficiency, allows for highest hygienic standards and reduces noise and vibration.

- **Item 1** - Unique APV spiral volute positioned in the backplate of the pump ensures a direct transfer of liquid from inlet to outlet
- **Item 2** - Advanced, high efficiency impeller design
- **Item 3** - Extended outlets smooth transition to process piping while reducing turbulence and preventing product build-up
- **Item 4** - Heavy walled pump casing insures that efficiency levels are maintained even at high pressure

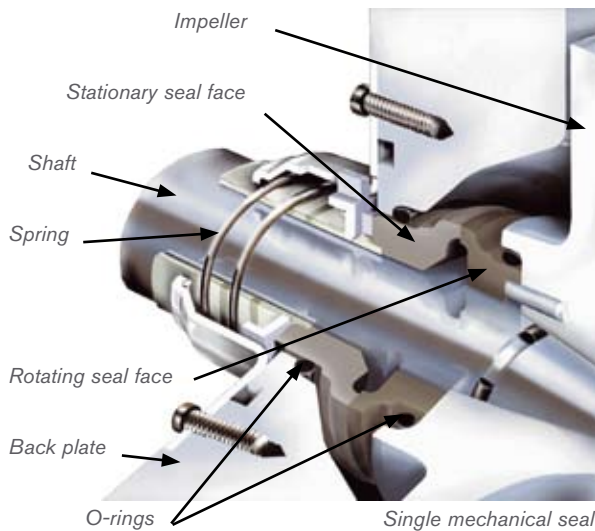

Single mechanical seal



Double mechanical seal prepared for flushing or a steam barrier

Special Shaft Designed for Hygienic Applications:

The shaft seal is the essential area in terms of hygiene. The pumps are equipped with a shaft seal that is ideal for hygienic applications.

Seal Advantages:

- Internal seal design optimizes cooling and lubrication of seal surfaces while the seal chamber is built to efficiently dissipate heat. Both work to reduce risk of "dry-running"
- Directed flow assures thorough cleaning of seal area
- The stationary spring is located outside the product contact area to maintain cleanliness
- Two sizes cover all models
- Front loading seal simplifies maintenance: only the pump housing and impeller have to be disassembled, then the shaft seal can be replaced quickly from the front
- Can easily be rebuilt into a double mechanical shaft seal for use with water flushing or with a barrier medium for aseptic applications
- Double mechanical is mirror image of single: same seal faces and O-rings

Pump Specifications

Materials	
Casing	SS 316L
Impeller	SS 316L
Impeller nut	SS 316L
Back plate	SS 316L
Shaft	SS 316L
Clamp ring	SS 304
Adaptor	SS 304
Support	SS 304
Shaft seal	Carbon/Silicon Carbide Optional: Silicon Carbide/Silicon Carbide
Elastomers	FKM Optional: EPDM, PTFE
Technical data	
Max. discharge pressure	260 psig (18 bar): W+10/8, W+22/20, W+30/80, W+35/55, W+35/35, W+110/130 200 psig (14 bar): W+25/210, W+30/120, W+50/8, W+55/35, W+55/60, W+60/110, W+65/350, W+70/40, W+80/80 Optional: Heavy duty clamping ring, increasing max. outlet pressure to 360 PSIG (25 bar): W+30/120, W+55/35, W+55/60, W+60/110, W+70/40 290 PSIG (20 bar): W+80/80
Max. operating temperature	203°F (95°C) as standard. >203°F, please contact SPX Flow Technology
Port connections	
Tri-clamp® connections are standard. Bevel seat, I-line, ISO and other standard fittings are available as well as special aseptic connections for sterile flushing of Wa+.	
Motor	
TEFC or Washdown enclosures available. Energy-efficient, Chem-duty, Explosion Proof and stainless steel also available, as well as single phase or three phase, 60 or 50 Hertz.	

Model	Inlet size		Outlet size		Maximum impeller size		Maximum capacity (GPM)		Maximum head (ft)	
	mm	Inch	mm	Inch	mm	Inch	1750 rpm	3500 rpm	1750 rpm	3500 rpm
10/8	38	1½	25	1	110	4.3	32	65	17	68
22/20	51	2	51	2	142	5.6	85	175	34	138
25/210	152	6	102	4	290	11.4	1610	-	134	-
30/80	102	4	76	3	170	6.7	315	650	43	171
30/120	102	4	76	3	175	6.9	410	810	47	190
35/35	65	2½	51	2	175	6.9	142	280	49	198
35/55	76	3	65	2½	180	7.1	230	465	50	200
50/8	38	1½	25	1	200	7.9	42	85	68	275
55/35	65	2½	38	1½	210	8.3	140	245	76	302
55/60	76	3	51	2	220	8.7	305	615	78	315
60/110	102	4	76	3	230	9.1	475	975	90	359
65/350	152	6	102	4	260	10.2	1250	2300	100	400
70/40	65	2½	38	1½	240	9.4	110	235	98	390
80/80	76	3	51	2	255	10	310	625	112	450
110/130	102	4	76	3	290	11.4	575	1050	150	600

A comprehensive range

The W+ range consists of 16 standard models with pressure and flow capacities to 217 psi (15 bar) and to 1,760 gpm (400 m³/hr), and a number of special versions which may be specifically adapted to customer requirements. The W+ pumps are modular so that any pumping job can be done with a perfectly customized W+ pump.

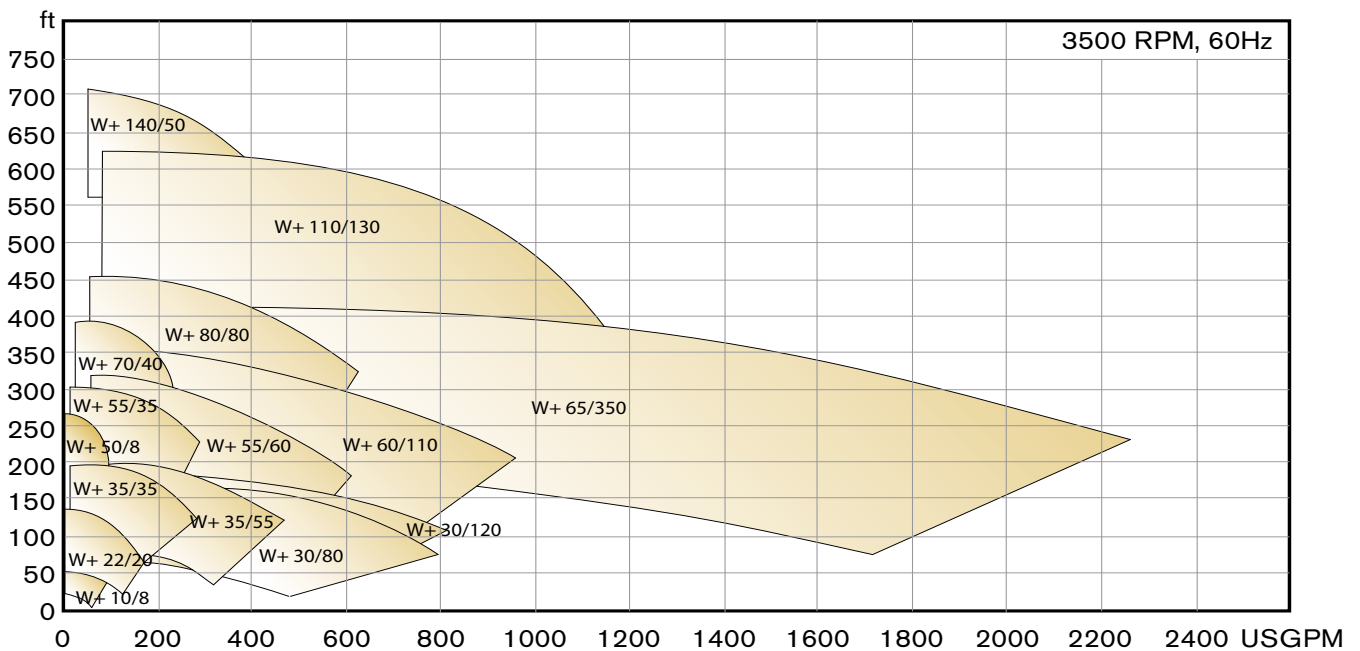
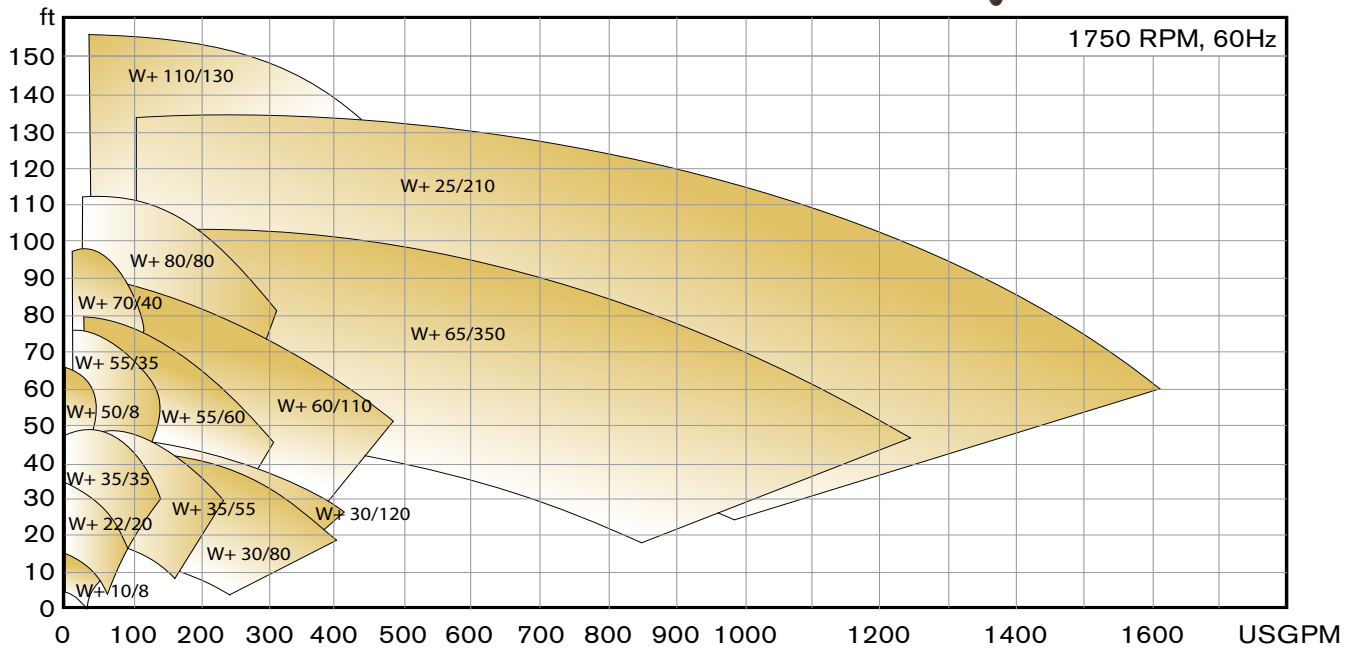

Variants of the W+

Wi+ Inducer Pump



The inducer pump is the alternative to changing the process design when NPSH availability is low. The inducer boosts the inlet pressure, and the risk of cavitation is correspondingly reduced (the NPSH required typically drops by 50-70%). When the risk of cavitation disappears, so does the risk of a large number of operational disturbances that would otherwise result - such as excessive noise, energy loss, product damage and unnecessary wear on the pump. Low suction head is a common “problem” in miscellaneous applications, e.g. when pumping products with low boiling points or in processes that involve vacuums.

The Wi+ is unique among inducer pumps, since the NPSH requirement is kept to a minimum throughout its entire operating range. The inducer further enables the Wi+ pump to handle viscous or gaseous products beyond the range of other centrifugal pumps.

Ws+ Self-Priming Pump



The self-priming Ws+ is designed to handle CIP return and other fluids with entrained air and foam. The unique design reduces the energy consumption and noise of traditional liquid ring pumps by using a high efficiency impeller that can be trimmed to match a specific duty. The Ws+ employs a built in eccentric air screw to form the liquid ring required for its self-priming capability.

Features and Benefits

- 20-90% more efficient than other liquid rings due to improved fluid flow through pump.
- Performance optimized by matching impeller size to duty.
- Low noise level: Due to its hydraulic design the noise level of the Ws+ is significantly lower than traditional liquid ring pumps.
- 3A and EHEDG approved.
- Interchangeable with W+ parts. Inventory is reduced by sharing common parts.
- Less prone to damage. Small objects can pass through pump with minimal damage.

W+ Multistage Pump

The W+140/50 offers three special features:



- Provides differential pressures up to 700 ft (15 bar)
- Can be used in processes with system pressures up to 870 psi (60 bar)
- Ensures optimum hygienic standards

And unlike other multistage pumps, it is CIP friendly. It has an open and semi-open impeller, eliminating any hiding place for bacteria. The W+ multistage pump is equipped with a heavy-duty bearing bracket that absorbs all radial and axial forces present in pumps of this kind. Therefore, the W+140/50 can use standard motors.

Whp+ High Pressure Pump



The Whp+ is a high-pressure model of the W+ range. The pumps are designed to withstand system pressures up to 870 psi (60 bar) — such as those in certain reverse osmosis systems. The Whp+ pump's sturdy construction increases stability and dampens vibrations.

Wa+ Aseptic Pump

Environmental requirements are getting stricter and stricter! But today, aseptic production is already essential to certain processes — including the manufacture of long life food and pharmaceutical products. The Wa+ pump is the perfect solution. All seals, including the shaft seal, are designed as double seals.

- Double mechanical shaft seals fitted for sterile flushing
- Double O-ring sealing of pump housing fitted for sterile flushing
- Special aseptic fittings fitted for sterile flushing



Aseptic fitting

So, Wa+ pumps products ensure absolutely aseptic production processes with barrier media up to 320°F (150°C). With a Wa+ pump, the risk of contaminating the product and environment is thus reduced to an absolute minimum.

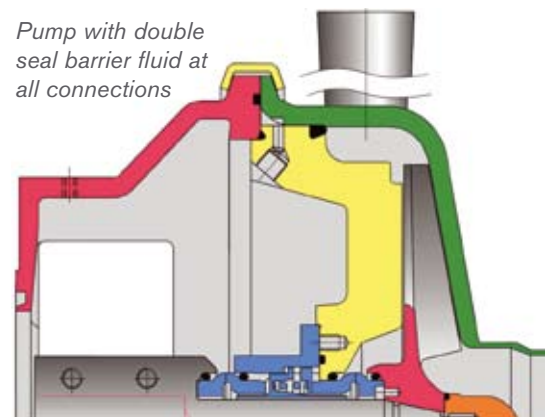

Pump with double seal barrier fluid at all connections

W+ for pharmaceutical applications like WFI and HPW

W+ pumps are also available in a pharmaceutical design where product contact parts (Impeller, impeller nut and back plate) are machined from solid 316L SS and electro polished. The deep-drawn, low ferrite casing is polished to 20 Ra contact surface finish and electro polished. Other optional features are casing drain, multiple outlet positions and certifications of materials and surface finish.



Your local contact:



SPX Flow Technology
611 Sugar Creek Road
Delavan, WI 53115

Phone: (262)728-1900 or (888)278-4321 Fax: (262)728-4904 or (800)252-5045

E-mail: answers.us@spx.com
www.apv.com
www.spxft.com

For more information about our worldwide locations, approvals, certifications, and local representatives, please visit www.gowcb.com.

SPX Corporation reserves the right to incorporate our latest design and material changes without notice or obligation.

Design features, materials of construction and dimensional data, as described in this bulletin, are provided for your information only and should not be relied upon unless confirmed in writing.

Issued: 06/2010 7016-01-04-2010-US

Copyright © 2010 SPX Corporation